

E-C

progesterone USP 100 mg and estradiol benzoate 10 mg

20 dose CARTRIDGE BELT*

For use with a COMPONENT Implanter**

For Use In Animals Only

Each CARTRIDGE BELT holds 20 doses of COMPONENT[®] E-C Implants. Each dose of 4 pellets contains a total of 100 mg progesterone USP and 10 mg estradiol benzoate. COMPONENT[®] E-C Implants are indicated for increased rate of weight gain in suckling beef calves up to approximately 400 lbs of body weight.

Do not use in veal calves. Effectiveness and animal safety in veal calves have not been established.

DOSAGE: Administer 1 implant per animal according to the following instructions.

GENERAL INSTRUCTIONS:

Study the instructions and follow them carefully at all times, avoiding shortcuts. Skin infection can be avoided by properly preparing implant site and implanter. One designated team member should always do the implanting. Cleanliness of hands and instruments is important at all times.

DO NOT USE IN BULL CALVES INTENDED FOR REPRODUCTION OR IN CALVES LESS THAN 45 DAYS OLD.

WARNING

Implant one dose — 4 pellets (entire contents of one cartridge cell) — in the ear subcutaneously. Any other site of implantation is in violation of Federal Law. DO NOT attempt to salvage implantation site for animal feed or human food.

A withdrawal period has not been established for this product in pre-ruminating calves. Do not use in calves to be processed for veal.

**RESTRICTED DRUG — USE ONLY AS DIRECTED (CALIFORNIA) —
FOR USE IN ANIMALS ONLY — NOT FOR HUMAN USE —
KEEP OUT OF REACH OF CHILDREN**

CAUTION:

Bulling, rectal and vaginal prolapse, udder development, ventral edema and elevated tailheads may be reported in calves administered progesterone and estradiol benzoate.

IMPLANTING INSTRUCTIONS:

Loading the Implanter

Load the implanter following the instructions supplied with each implanter.

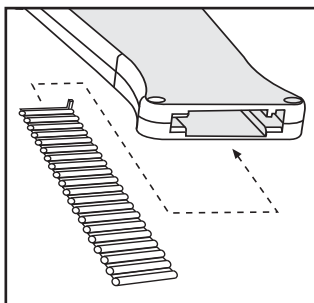

Restrain the Animal

Speed of implantation as well as safety of handlers is best achieved by restraining animal in a squeeze chute using head restraint.

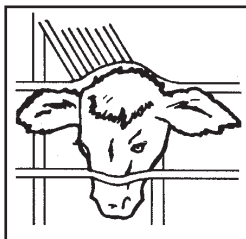

Prepare the Implant Site

Scrub the back side of the ear (implant site) with a piece of clean absorbent cotton or brush which has been soaked with topical germicidal solution. Follow manufacturer's directions on germicide for correct strength and preparation of solution. Avoid getting disinfectant in animal's eyes.



Where to Implant

The full contents of one cartridge cell should be implanted beneath the skin on the back side of the middle one-third of the ear as illustrated in the drawing. The implant must not be closer to the head than the edge of the auricular cartilage ring farthest from the head. The location for insertion of the needle is a point toward the tip of the ear and at least a needle length away from the intended deposition site. Avoid injuring the large arteries, veins and cartilage of the ear.

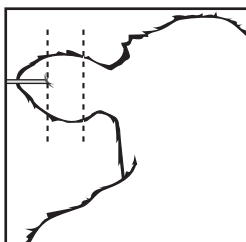

Insert the Needle

With one hand firmly grasp the ear. With the other hand insert needle point through the skin and ease forward on a lateral plane until the entire length of the needle is under the skin.

Implant the Pellets

Follow the directions contained in the implanter packaging to ensure the pellets are properly deposited. Proper procedure should prevent breakage or crushing of pellets. The length and total contact area of a single dose are designed to permit absorption of the hormones after implantation to stimulate weight gain. Broken or crushed pellets may interfere with rates of gain and may lead to undesirable side effects such as noted in the CAUTION.

Clean the Needle

Clean the implanter needle with alcohol or a properly diluted germicidal solution prior to implanting the next animal.

Storage Conditions

Store at controlled room temperature 15° to 30°C (59° to 86°F)
Avoid excessive heat and humidity.

NADA 110-315, Approved by FDA

Manufactured by a non-sterilizing process.

*U.S. Patent No. 4,531,938

**U.S. Patent Nos. 4,762,515 & 5,522,797 – Ivy Animal Health, Inc.

COMPONENT and COMPONENT One Gun are registered trademarks of Ivy Animal Health, Inc.

Manufactured for **VetLife** by Ivy Laboratories.

Overland Park, KS 66214, USA

VetLife and Ivy Laboratories are divisions of Ivy Animal Health, Inc.