

**COMPONENT**®  
BRAND IMPLANTS

**VetLife**®  
STEER IMPLANTS

# E-S

progesterone USP 200 mg and  
estradiol benzoate 20 mg

## 20 dose CARTRIDGE BELT\*

For use with the COMPONENT One Gun®\*\*  
**For Use In Animals Only**

Each CARTRIDGE BELT holds 20 doses of COMPONENT® E-S Implants. Each dose of 8 pellets contains a total of 200 mg progesterone USP and 20 mg estradiol benzoate. COMPONENT® E-S Implants are recommended for use in steers weighing 400 lbs or more for INCREASED RATE OF WEIGHT GAIN AND IMPROVED FEED EFFICIENCY.

Do not use in veal calves. Effectiveness and animal safety in veal calves have not been established.

**DOSAGE:** Administer 1 implant per animal according to the following instructions.

**GENERAL INSTRUCTIONS:** Study the instructions which should be followed carefully at all times, avoiding short cuts. Skin infection can be avoided by properly preparing implant site and implanter. During fly season use fly repellent on implant site. One designated team member should always do the implanting. Cleanliness of hands and instruments is important at all times.

### WARNING

**Not to be used in animals intended for subsequent breeding, or in dairy animals.** Implant one dose — 8 pellets (entire contents of one cartridge cell) — in the ear subcutaneously. Any other site of implantation is in violation of Federal Law. **DO NOT** attempt to salvage implantation site for animal feed or human food.

**A withdrawal period has not been established for this product in pre-ruminating calves. Do not use in calves to be processed for veal.**

**RESTRICTED DRUG — USE ONLY AS DIRECTED (CALIFORNIA) —  
FOR USE IN ANIMALS ONLY — NOT FOR HUMAN USE —  
KEEP OUT OF REACH OF CHILDREN**

### CAUTION:

Bulling, rectal prolapse, ventral edema and elevated tail-heads have occasionally been reported in animals implanted with progesterone and estradiol benzoate.

### IMPLANTING INSTRUCTIONS:

#### Loading the Implanter

Load the implanter following the instructions supplied with each implanter.

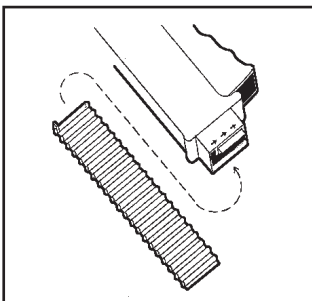
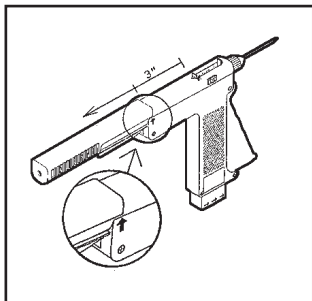

### Restrain the Animal

Speed of implantation as well as safety of handlers is best achieved by restraining animal in a squeeze chute using head restraint. When implanting horned cattle, better control is obtained with additional use of nose tongs.

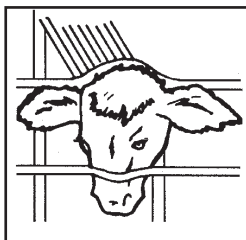

### Prepare the Implant Site

Scrub the back side of the ear (implant site) with a piece of clean absorbent cotton which has been soaked with topical germicidal solution. Follow manufacturer's directions on germicide for correct strength and preparation of solution. Avoid getting disinfectant in animal's eyes.



### Where to Implant

The full contents of one cartridge cell should be implanted beneath the skin on the back side of the middle one-third of the ear as illustrated in the drawing. The implant must not be closer to the head than the edge of the auricular cartilage ring farthest from the head. The location for insertion of the needle is a point toward the tip of the ear and at least a needle length away from the intended deposition site. Avoid injuring the large arteries, veins and cartilage of the ear.

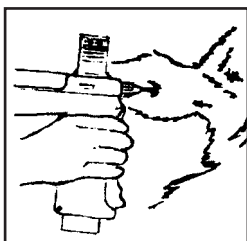

### Insert the Needle

With one hand firmly grasp the ear. With the other hand insert needle point through the skin and ease forward on a lateral plane until the entire length of the needle is under the skin.

### Implant the Pellets

After inserting the needle fully in the correct implant position squeeze the trigger fully. As the needle is withdrawn from the ear, the controlled-pressure plunger action properly deposits the implant in the needle track. This procedure should prevent breakage or crushing of pellets if otherwise forced into contact with tough fibrous-tissue underlying the skin. The length and total contact area of a single dose are designed to permit absorption of the hormones after implantation to stimulate good weight gain. Broken or crushed pellets may interfere with rates of gain and may lead to undesirable side effects such as noted in the CAUTION.

### Clean the Needle

Clean the implanter needle with alcohol or a properly diluted germicidal solution prior to implanting the next animal.

### Storage Conditions

Store at controlled room temperature 15° to 30° C (59° to 86° F)

**DO NOT refrigerate** – avoid excessive heat and humidity.

NADA 110-315, Approved by FDA

**Manufactured by a non-sterilizing process.**

\*U.S. Patent No. 4,531,938

\*\*U.S. Patent Nos. 4,762,515 & 5,522,797 – Ivy Animal Health, Inc.

COMPONENT and COMPONENT One Gun are registered trademarks of Ivy Animal Health, Inc.

Manufactured for **VetLife** by Ivy Laboratories.

Overland Park, KS 66214, USA

VetLife and Ivy Laboratories are divisions of Ivy Animal Health, Inc.